

Bobtot



Quick Setup Guide B89

5.1 CHANNEL HOME THEATER SYSTEM



Scan the QR code to access how-to videos, the user's manual, and other important information you may need to get the most of your item



Like our product?

Share your experience with our customers on your page!



Having troubles?

Contact us: service@bobtot.net

What's in the box

*Subwoofer Speaker	1PC
*Satellite Speakers(Center & FL & FR & SL & SR)	5PCS
*RCA Video Audio Cables	3PCS
*3.5mm to RCA Audio Stereo Cable	1PC
*TV ARC Cable	1PC
*Optical Audio Cable	1PC
*Coaxial Cable	1PC
*Remote Control	1PC
*FM Antenna Cable	1PC
*User Manual	1PC

IMPORTANT SAFETY INSTRUCTIONS



TO REDUCE THE RISK OF ELECTRICAL SHOCK, DO NOT REMOVE AMPLIFIER PLATE. NO USER SERVICEABLE PARTS INSIDE. WE RECOMMEND TAKING THE UNIT TO A QUALIFIED SERVICE TECHNICIAN FOR ANY REPAIRS.



Read the following safety instructions before operating your home theater system.

- Do not place these speakers on an unstable surface. The speaker may fall over, causing serious injury to a child or adult and serious damage to the unit.
- Do not use these speakers near water or expose them to rain or moisture.
- The speakers should be situated away from heat sources such as radiators, heat registers, stoves, or other devices that produce heat.
- Please use under specified voltage(120V/60Hz). Any other voltage than the specified voltage may cause fire or electric shock.
- To reduce the risk of electric shock or component damage, unplugged the power before moving your speakers or connecting other components to your device.
- Clean only with a soft dry cloth. Unplug the main unit from the wall outlet before cleaning.

CAUTION: Always use a power outlet that is properly grounded.

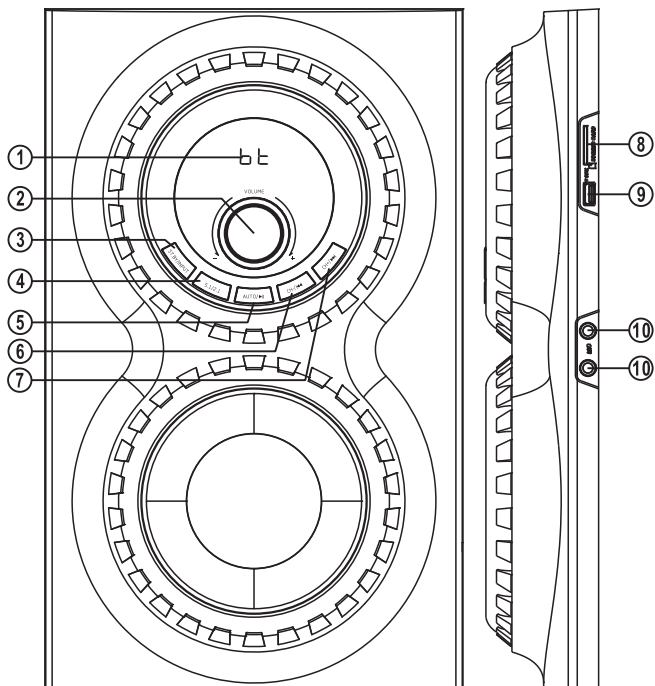
FRONT PANEL OF SUBWOOFER



- ① Digital Display
- ② VOLUME-----Turn the knob to decrease or increase the volume
- ③ ST.BY ----- Stand by function by pressing it 3 secs in
AUX/USB/FM/BT/OPTICAL/COAXIAL
/TV ARC mode.
INPUT ----- Input function key, switch among AUX
/USB/DVD/FM/BT/OPTICAL/ COAXIAL
/TV ARC mode.
- ④ 5.1/2.1-----5.1/2.1 function key.
- ⑤ AUTO/  -----Pause/Play function key.
When the FM state when the automatic
search and save the radio station.
- ⑥ CH-/  ----- "Previous" function key.
Previous song when USB/SD input;
Previous channel when FM input;
- ⑦ CH+/  -----"Next" function key.
Next song when USB/SD input;
Next channel when FM input;
- ⑧ SD/MMC CARD-----SD card socket (max file size 64Gb)
- ⑨ U DISK-----USB socket (max file size 64Gb)
- ⑩ MIC -----MIC 1 & 2 socket

BACK PANEL OF SUBWOOFER

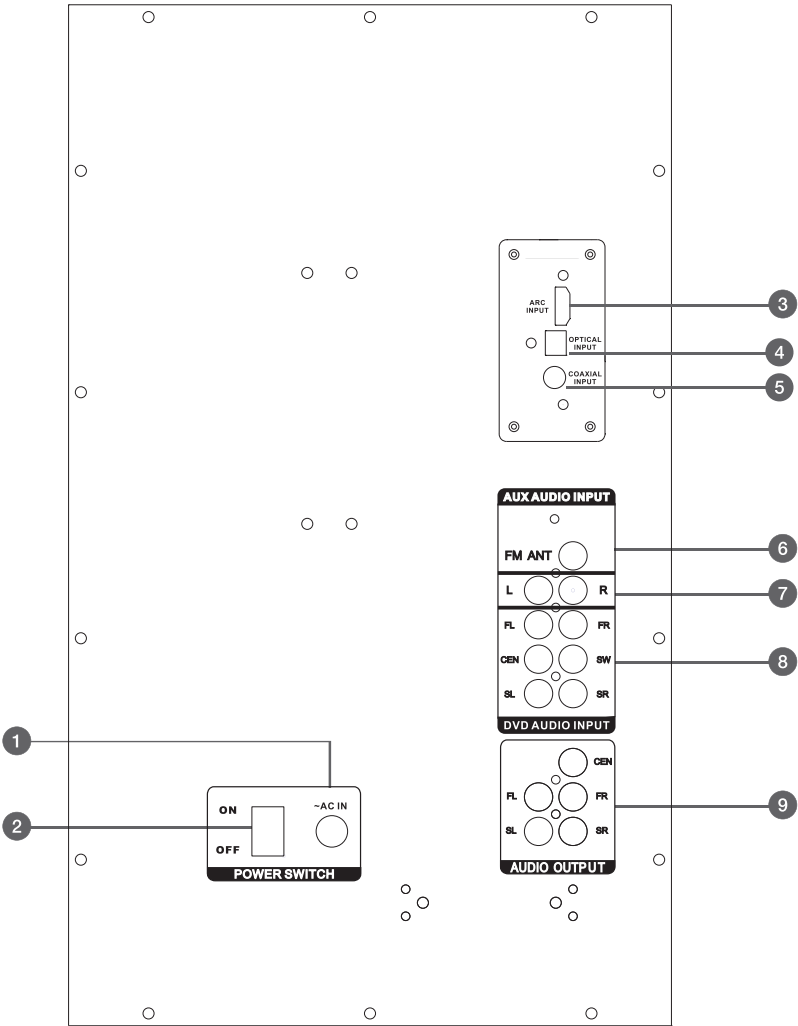

1. Power input
2. Power switch
3. TV ARC audio input
4. Optical audio input
5. Coaxial audio input
6. FM antenna
7. RCA to RCA or RCA to 3.5mm AUX audio input
8. 3PCS RCA DVD audio input (front L&R/center/subwoofer/rear L&R)
9. Center/Front L/R/Rear L/R audio output

REMOTE CONTROL FUNCTIONS

 : Power/Standby

INPUT: Switch between input modes:USB/SD/FM/
AUX/DVD/OPT/COA/TV ARC/BT

MUTE: Mute all output

5.1/2.1: Channel mode select

SLEEP-/+ : Setting the sleep time

SAVE: Save stations to unit memory

TUNE+/-: Manually tune FM stations

 : Play/Pause in USB/SD/BT modes

AUTO: Automatic station search

CH-/ :Previous FM station/previous track(USB/SD)

CH+/ :Next FM station/next track(USB/SD)

FL+/-: Front left speaker volume control

FR+/-: Front right speaker volume control

SW+/-: Subwoofer volume control

CEN+/-: Center speaker volume control

VOL+/-: Master volume control

SL+/-: Rear satellite left speaker volume control

SR+/-: Rear satellite right speaker volume control

0-9: Number pad used to direct select tracks when
in USB/SD mode

REPEAT: Repeat one song/repeat all songs/shuffle

RESET: Reset volume level

MIC+/- (EQ+/-):when a pair of microphone are connected,
these buttons will control the mic volume. In USB/SD mode,
they will allow you to navigate the 5 preset EQ curves. Please
note: connecting mics will override the EQ+/- function.

ECHO+/- (DISP+/-):when a pair of microphone are connected,these buttons
will control the echo effect. If there are no mics connected,
they will control the display brightness. Please note:
connecting mics will override the DISP+/- function.

NOTE:

1. Turn on the unit, please press the "Power" button before selecting the input mode.
2. If the remote control does not work, please replace the batteries and try again.

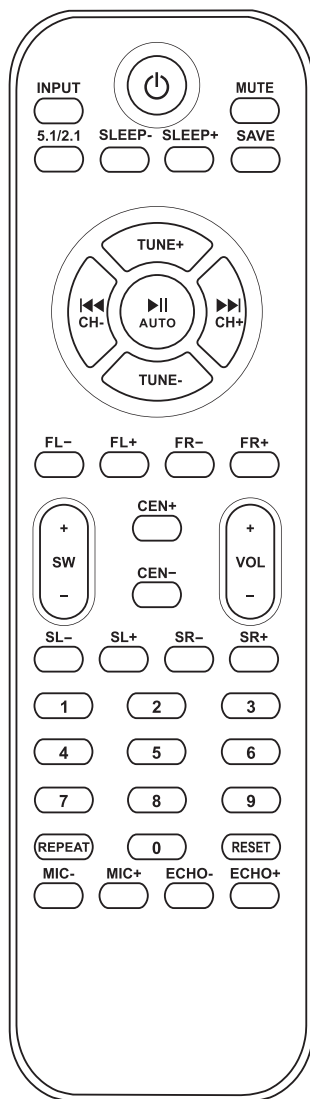

BEST PLACEMENT FOR 5.1 Home Theater System

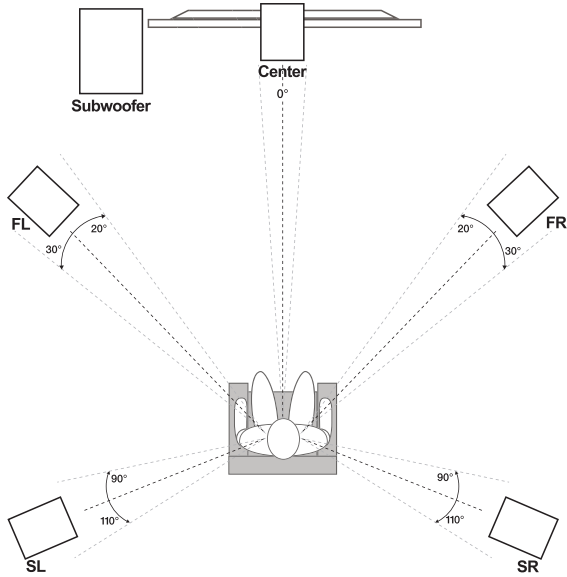

SET UP CENTER & FRONT & REAR SPEAKERS

Center Speaker
Cable:157.48inch

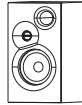

FL Speaker
Cable:157.48inch

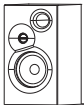

FR Speaker
Cable:157.48inch

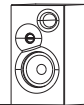

SL Speaker
Cable:472.44inch

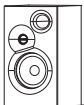

SR Speaker
Cable:472.44inch

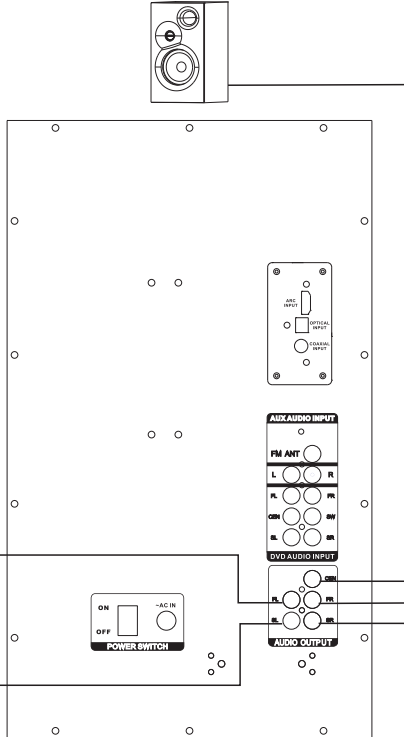
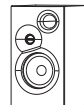

SYSTEM CONNECTION DIAGRAM

Verify that your device can be used to input sound from audio/video for other external sound source devices, and ensure your device have an available jack to match the appropriate port on the subwoofer.

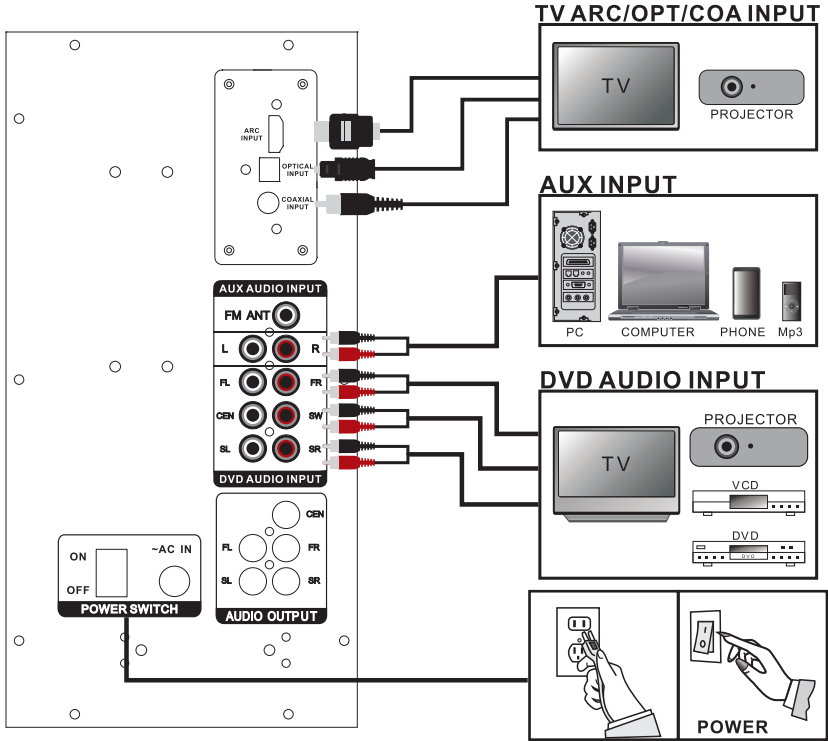

How to use the wireless BT

1. Make sure the 5pcs speakers are plugged into the audio output sockets of subwoofer and power " **ON** " status.
2. Press the " **ST.BY** " button before selecting the mode.
3. Press the " **INPUT** " button to switch mode to " **BT** " status, which is showing in the LED display of the subwoofer.
4. Search BT device with name " **Bobtot B89** "
5. Connect the BT

Note: If your BT device is below 2.0 version, input password " 0000 " when connecting.

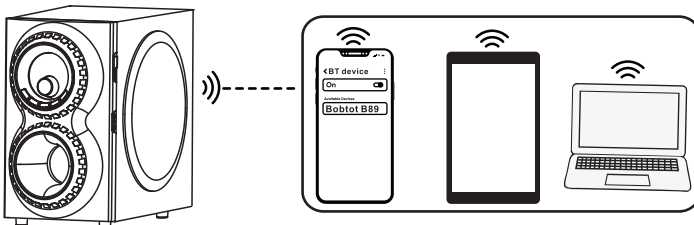

How to connect your device by TV ARC Cable

1. Plug the TV ARC cable into the ARC Input socket in back of the subwoofer, another port plug into the slot of your TV.
2. Make sure the 5pcs speakers are plugged into the audio output sockets of subwoofer and power " **ON** " status.
3. Press the " **ST.BY** " button before selecting the mode.
4. Press the " **INPUT** " button to switch mode to " **ARC** " status, showing in the LED display of the subwoofer.
5. TV setting: Sound output --- Select " **TV ARC** " .
6. TV setting: Expert Setting --- Digital output audio format--Select " **PCM** " .

Note: B89 ARC output only supports LPCM 2.0 audio format.



How to connect your device by Optical Cable

1. Take off the transparent cover of Optical Cable before plugging in.
2. Plug the Optical cable into the Optical Input socket in back of the subwoofer, another port plug into the slot of your TV.
3. Make sure the 5pcs speakers are plugged into the audio output sockets of subwoofer and power " **ON** " status.
4. Press the " **ST.BY** " button before selecting the mode.
5. Press the " **INPUT** " button to switch mode to " **OPT** " status, showing in the LED display of the subwoofer.
6. TV setting: Sound output --- select " **Optical** " .
7. TV setting: Expert Setting --- Digital output audio format--Select " **PCM** " .



How to connect your device by Coaxial Cable

1. Plug the Coaxial cable into the Coaxial Input socket in back of the subwoofer, another port plug into the slot of your device.
2. Make sure the 5pcs speakers are plugged into the audio output sockets of subwoofer and power " **ON** " status.
3. Press the " **ST.BY** " button before selecting the mode.
4. Press the " **INPUT** " button to switch mode to " **COA** " status, showing in the LED display of the subwoofer.
5. TV setting: Sound output --- Select " **Coaxial** " .
6. TV setting: Expert Setting --- Digital output audio format--Select " **PCM** " .



How to connect your device by RCA Stereo Audio Cable

1. Plug the RCA Stereo Audio cable in back of the subwoofer. White to White Connector, Red to Red Connector, another (White/Red) port plug into the L&R Output slots of your device.
2. Make sure the 5pcs speakers are plugged into the audio output sockets of subwoofer and power "**ON**" status.
3. Press the "**ST.BY**" button before selecting the mode.
4. Press the "**INPUT**" button to switch mode to "**AU**" status, showing in the LED display of the subwoofer.

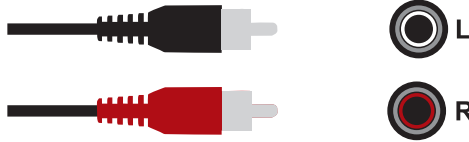

How to connect your device by 3.5mm to RCA Audio Stereo Cable

1. Plug the RCA L/R Stereo Audio cable in back of the subwoofer, White to White Connector, Red to Red Connector, and 3.5mm AUX port plug into the Headphone Output slot of your device.
2. Make sure the 5pcs speakers are plugged into the audio output sockets of subwoofer and power "**ON**" status.
3. Press the "**ST.BY**" button before selecting the mode.
4. Press the "**INPUT**" button to switch mode to "**AUX**" status, showing in the LED display of the subwoofer.



How to connect your device by 3RCA Audio Stereo Cable

1. Plug the 3RCA Stereo Audio cable in back of the subwoofer, White to White Connector, Red to Red Connector
2. Make sure the 5pcs speakers are plugged into the audio output sockets of subwoofer and power "**ON**" status.
3. Press the "**ST.BY**" button before selecting the mode.
4. Press the "**INPUT**" button to switch mode to "**DV**" status, showing in the LED display of the subwoofer.

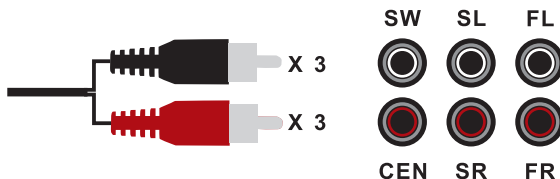

Certification

FCC Warning

This device complies with part 15 of the FCC Rules. Operation is subject to the following two conditions:

- (1) This device may not cause harmful interference, and
- (2) this device must accept any interference received, including interference that may cause undesired operation.

Any Changes or modifications not expressly approved by the party responsible for compliance could void the user's authority to operate the equipment.

Note: This equipment has been tested and found to comply with the limits for a Class B digital device, pursuant to part 15 of the FCC Rules. These limits are designed to provide reasonable protection against harmful interference in a residential installation.

This equipment generates uses and can radiate radio frequency energy and, if not installed and used in accordance with the instructions, may cause harmful interference to radio communications. However, there is no guarantee that interference will not occur in a particular installation. If this equipment does cause harmful interference to radio or television reception, which can be determined by turning the equipment off and on, the user is encouraged to try to correct the interference by one or more of the following measures:

- Reorient or relocate the receiving antenna.
- Increase the separation between the equipment and receiver.
- Connect the equipment into an outlet on a circuit different from that to which the receiver is connected.
- Consult the dealer or an experienced radio/TV technician for help.

This equipment complies with FCC radiation exposure limits set forth for an uncontrolled environment.

This equipment should be installed and operated with minimum distance 20cm between the radiator & your body.

Need Help ?

Customer Care Guide

At our company, we strive to provide exceptional customer care to every one of our clients. We believe that building strong relationships with our customers is essential to the success of our business. To help us achieve this goal, we have put together the following customer care guide.

Time

We understand that our customers' time is valuable, so we will respond to any inquiries within 24 hours.

Feedback

We know that our customers are the heart of our business so we value your feedback. We encourage you to share your thoughts and ideas with us.

Solutions

If our customers encounter any issues, we will try our best to find a quick and efficient solution that meets your needs.

Here at Bobtot, we take customer care very seriously. Our customers are our first priority, and we are committed to providing the highest quality service. If you have any questions or concerns, please don't hesitate to reach out to us. We will be happy to assist you:

Call or Message: **+1(888) 572-1718**

Email: **service@bobtot.net**

bobtot.net

Bobtot